

ROADBOOK

Carnet d'itinéraire

FFSA

ASA-ALES

50^{ème}

RALLYE DU GARD

AGGLOMÉRATION

16 / 17 JUIN 2023

VENEZ VIVRE UN MOMENT HISTORIC

VHRS - VMRS - VHC - MODERNE - LEGEND

ASA-ALES
Associazione Operativa Automobile

GT2i

POLE
MECASSIS

ADS
PÉRISSOLS





















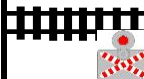

ALÈS
AGGLOMÉRATION

ALÈS
CÈVENNES

GARD

UN MOMENT HISTORIC

LEGENDE DES SYMBOLES

SRP Suivre Route Principale	 Chemin de terre
ES Epreuve Spéciale	 N°Poste Commissaire P avec chiffres
 CH Contrôle Horaire: se référer à votre feuille de route	 Feux tricolore
 DES Départ Epreuve Spéciale	 Passage sous pont ou portail Pôle Mécanique
CP Contrôle Passage 	POINT STOP Arrêt obligatoire après AES
 AES Arrivée lancée Epreuve Spéciale	 Passage sur pont
 Rond Point	 Bâtiment, maison... Place, Parking ...
 Route à suivre	 Traversée de voie ferrée
 Route à ne pas suivre	ville Direction à suivre
 VILLE Entrée de ville(age)	 ville Direction à ne pas suivre
 VILLE Sortie de ville(age)	 Matérialise votre position
 Fin zone casquage	 Zone casquage
 Assistance interdite	 Assistance autorisée



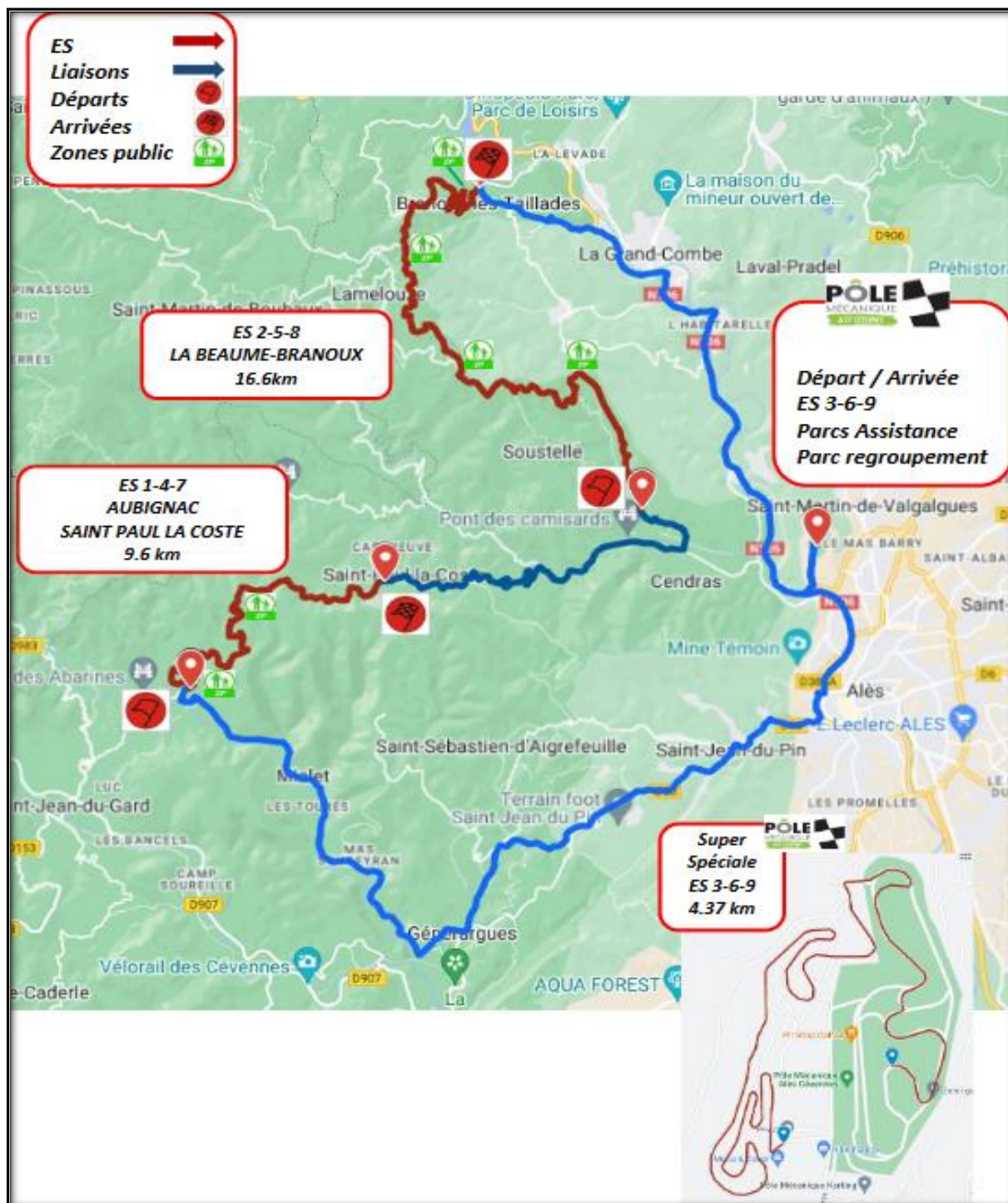





CARTE GENERALE













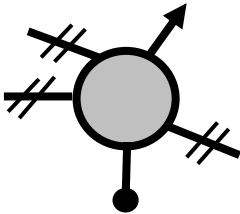

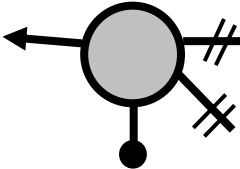

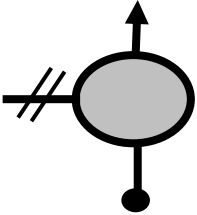

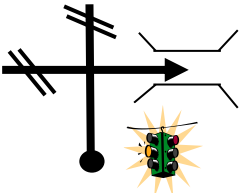



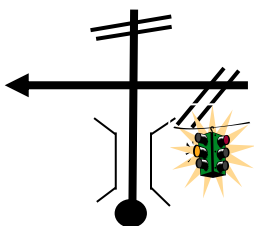

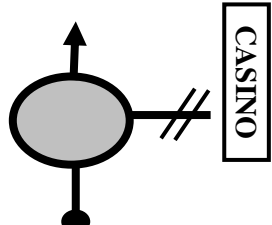
TIMING

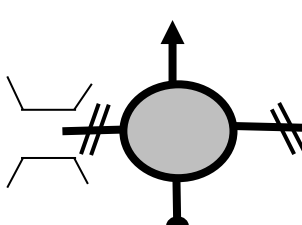

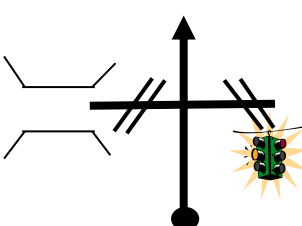

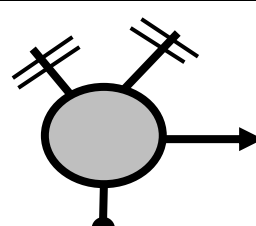





50 ème Rallye National du Gard - Alès Agglomération						
RALLYE DU GARD VHRS-VMRS-LEGEND-VHC-MODERNE						
ITINERAIRE et CONTRÔLES (Les horaires sont à titre indicatif)						
ETAPE 1 Samedi 17 Juin 2023						
CH	Lieux	ES	Liaison	Total	T.I.	1ère voit
ES		Distance	Distance	Distance		
CH 0	Sortie Parc Fermé Pôle Mécanique					07:30
CH 0	Entrée assistance					07:30
Assistance Pôle Mécanique		0,00	0,00	0,00	00:20	
CH 0A	Sortie Assistance		0,00	0,00		07:50
RZ	Refuel	0,00	0,00	0,00		
1	Prochain Refuel	30,98	49,24	80,23		
CH 1			24,64	24,64	00:50	08:40
ES 1	Aubignac - Saint Paul la Coste	9,606			00:03	08:43
CH 2			9,52	19,13	00:30	09:13
ES 2	La Baume - Branoux	17,007			00:03	09:16
CH 3			14,58	31,59	00:40	09:56
ES 3	Super Spéciale Pôle Mécanique	4,370			00:03	09:59
CH 3A	Entrée Regroupement Pôle Mécanique		0,50	4,87	00:08	10:07
Regroupement Pôle Mécanique 0H35						
CH 3B	Sortie Regroupement				00:35	10:42
CH 3B	Entrée Assistance					
Assistance Pôle Mécanique		30,98	49,24	80,23	00:45	
CH 3C	Sortie Assistance					11:27
RZ	Refuel	0,00	0,00	0,00		
2	Prochain Refuel	30,98	49,24	80,23		
CH 4			24,64	24,64	00:50	12:17
ES 4	Aubignac - Saint Paul la Coste	9,606			00:03	12:20
CH 5			9,52	19,13	00:30	12:50
ES 5	La Baume - Branoux	17,007			00:03	12:53
CH 6			14,58	31,59	00:40	13:33
ES 6	Super Spéciale Pôle Mécanique	4,370			00:03	13:36
CH 6A	Entrée Regroupement Pôle Mécanique		0,50	4,87	00:08	13:44
Regroupement Pôle Mécanique 0H35						
CH 6B	Sortie Regroupement				00:35	14:19
CH 6B	Entrée Assistance					
Assistance Pôle Mécanique		30,98	49,24	80,23	00:45	
CH 6C	Sortie Assistance					15:04
RZ	Refuel	0,00	0,00	0,00		
3	Prochain Refuel	30,98	49,24	80,23		
CH 7			24,64	24,64	00:50	15:54
ES 7	Aubignac - Saint Paul la Coste	9,606			00:03	15:57
CH 8			9,52	19,13	00:30	16:27
ES 8	La Baume - Branoux	17,007			00:03	16:30
CH 9			14,58	31,59	00:40	17:10
ES 9	Super Spéciale Pôle Mécanique	4,370			00:03	17:13
CH 9A	Entrée Parc Final		0,50	4,87	00:08	17:21
Total général		92,949	147,73	240,68		38,62%



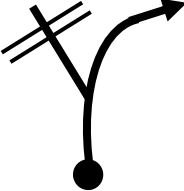

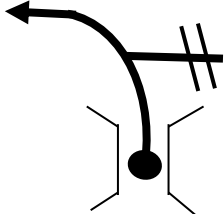





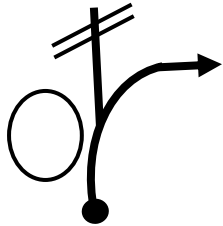



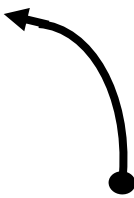



Coucher du soleil 21:30

ETAPE 1		POLE MECANIQUE	CH 0/3/6	Distance TOTALE	24,64
		à		Temps Imparti (H,mn)	0H50
SECTION 1/2/3		POLE MECANIQUE	CH 0A/3C/6C	Moyenne Horaire	29,57
DISTANCE		DIRECTION	INFORMATIONS		
TOTALE	PARTIELLE				DISTANCE TOTALE DEGRESS.
		 1		CH  SORTIE PARC FERME	
		 2		ENTREE ASSISTANCE	
		 3		CH  SORTIE ASSISTANCE	

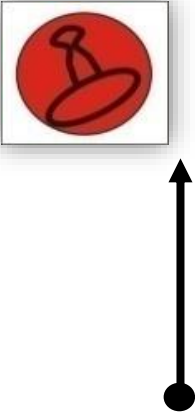
ETAPE 1		POLE MECANIQUE à AUBIGNAC		CH 0A/3C/6C	Distance TOTALE	24,64
SECTION 1/2/3				CH 1/4/7	Temps Imparti (H,mn)	0H50
DISTANCE		DIRECTION		INFORMATIONS		DISTANCE TOTALE
TOTALE	PARTIELLE					DEGRESS.
0,00	0,00	↑			CH  SORTIE ASSISTANCE	24,64
0,06	0,06				MEUDE →	24,58
0,26	0,20				N 106 ALES - CENTRE →	24,38
1,85	1,59				N 106 NIMES AVIGNON MONTPELLIER →	22,79
2,33	0,48				NIMES AVIGNON MONTPELLIER →	22,31

ETAPE 1		POLE MECANIQUE à AUBIGNAC		CH 0/3/6	Distance TOTALE	24,64
SECTION 1/2/3				CH 1/4/7	Temps Imparti (H,mn)	0H50
DISTANCE		DIRECTION		INFORMATIONS		DISTANCE TOTALE
TOTALE	PARTIELLE					DEGRESS.
2,45	0,12					22,19
2,73	0,28					21,91
3,47	0,74					21,17
3,75	0,28					20,89
4,00	0,25				 	20,64







ETAPE 1		POLE MECANIQUE à AUBIGNAC		CH 0/3/6	Distance TOTALE	24,64
SECTION 1/2/3				CH 1/4/7	Temps Imparti (H,mn)	0H50
DISTANCE		DIRECTION		INFORMATIONS		DISTANCE TOTALE
TOTALE	PARTIELLE					DEGRESS.
5,72	1,72			D 50 St JEAN du PIN	SRP	18,92
6,88	1,16			D 50 St JEAN du PIN	SRP	17,76
9,92	3,04			St JEAN du GARD GENERARGUES		14,72
12,05	2,13			D 50 St JEAN du GARD		12,59
13,94	1,89			D 50 GENERARGUES		10,70

ETAPE 1		POLE MECANIQUE à AUBIGNAC		CH 0/3/6	Distance TOTALE	24,64
SECTION 1/2/3				CH 1/4/7	Temps Imparti (H,mn)	0H50
DISTANCE		DIRECTION		INFORMATIONS		DISTANCE TOTALE
TOTALE	PARTIELLE					DEGRESS.
14,08	0,14			 		10,56
17,55	3,47			  SRP		7,09
20,23	2,68			 		4,41
23,72	3,49		 	  		0,92

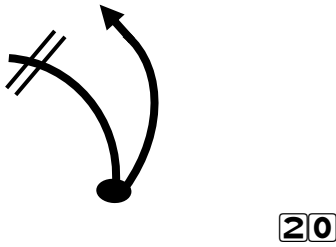
Rallye National du Gard - Alès Agglomération

PAGE

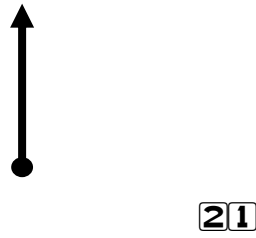
9

ETAPE 1		POLE MECANIQUE		CH 0/3/6	Distance TOTALE	24,64
SECTION 1/2/3		à AUBIGNAC		CH 1/4/7	Temps Imparti (H,mn)	0H50
					Moyenne Horaire	29,57
DISTANCE		DIRECTION		INFORMATIONS		DISTANCE TOTALE
TOTALE	PARTIELLE					DEGRESS.
24,46	0,74				D 160  	0,18
24,64	0,18				CH  ES 1/4/7	0,00





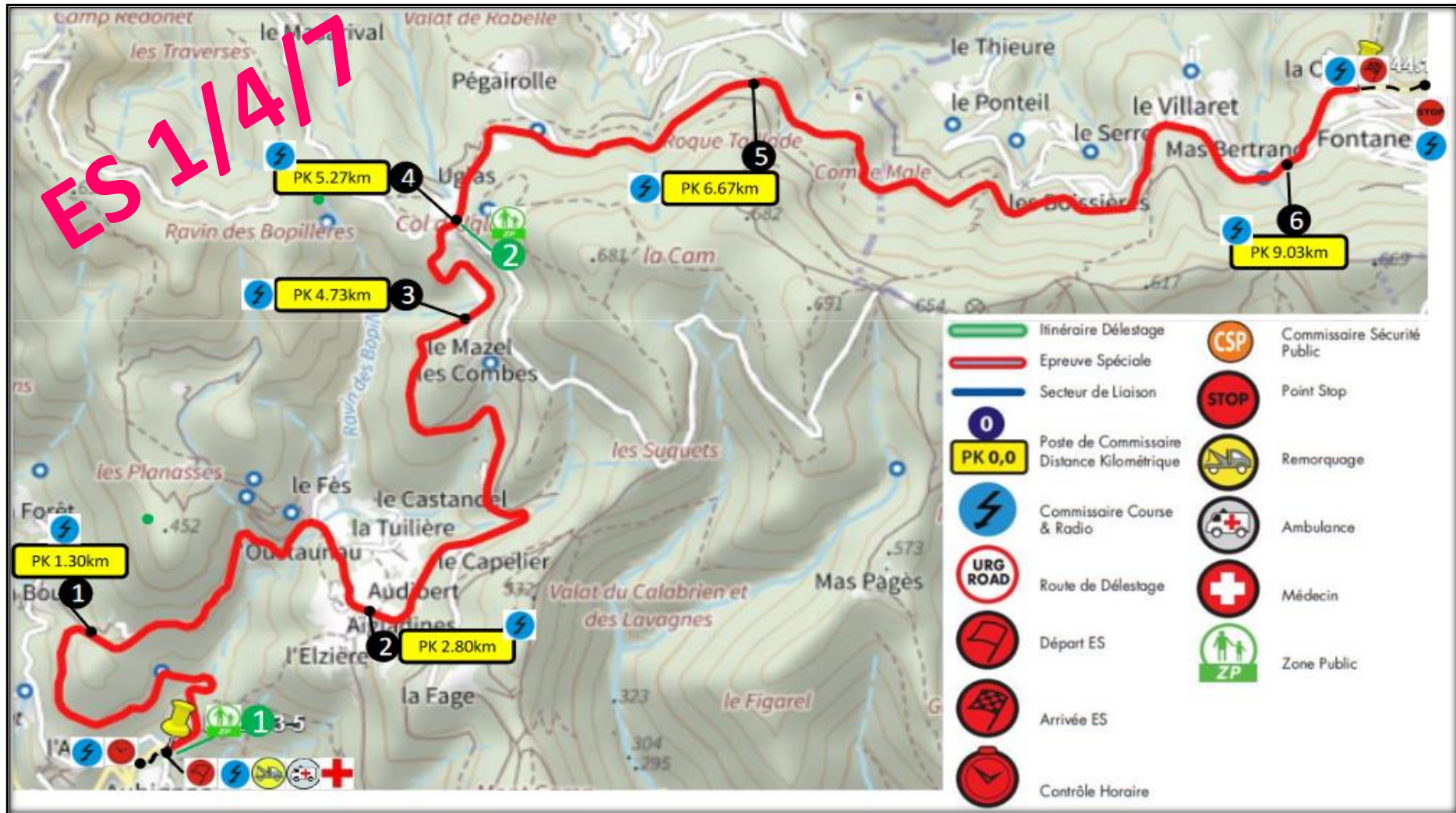





AUBIGNAC - ST PAUL LACOSTE

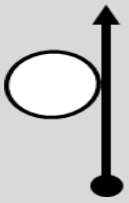

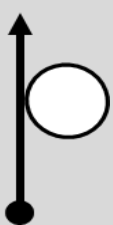

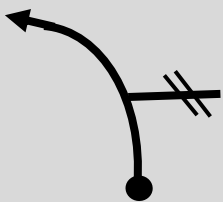

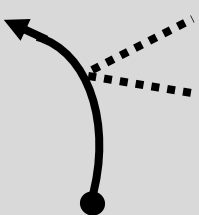

9,606 Km

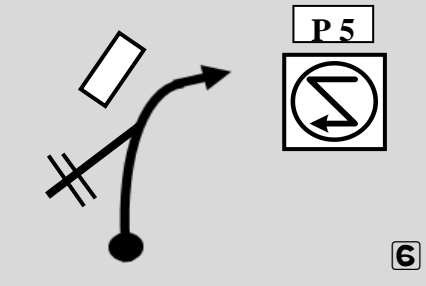

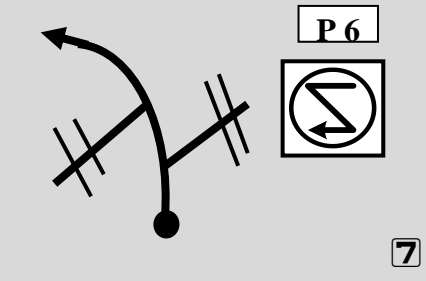

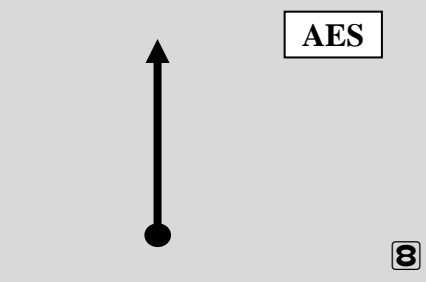

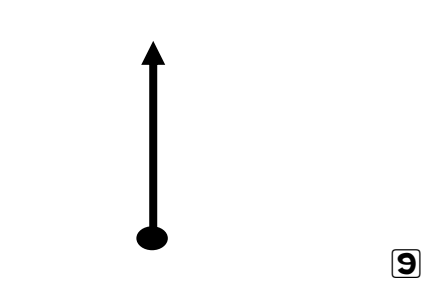











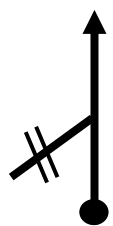

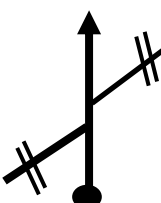



ETAPE	1	AUBIGNAC à	CH 1/4/7	Distance TOTALE	0H03
SECTION	1/2/3	ST PAUL LACOSTE	ES 1/4/7	Temps Imparti (H,mn)	
				Moyenne Horaire	

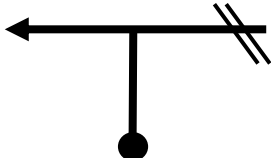

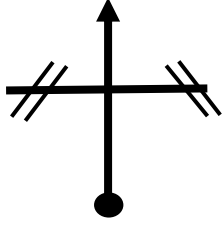
ETAPE 1		AUBIGNAC à LA BAUME		ES 1/4/7	Distance TOTALE	19,13
SECTION 1/2/3				CH 2/5/8	Temps Imparti (H,mn)	0H30
					Moyenne Horaire	38,26
DISTANCE		DIRECTION		INFORMATIONS		DISTANCE TOTALE
TOTALE	PARTIELLE					DEGRESS.
0,000	0,000	 1			 DES 1/4/7	19,130
1,307	1,307	 <div style="display: flex; justify-content: space-between;"> P1  </div> 2				17,823
2,872	1,565	 <div style="display: flex; justify-content: space-between;"> P2  </div> 3				16,258
4,825	1,953	 <div style="display: flex; justify-content: space-between;"> P3  </div> 4				14,305
5,385	0,560	 <div style="display: flex; justify-content: space-between;"> P4  </div> 5				13,745

ETAPE 1		AUBIGNAC à LA BAUME		ES 1/4/7	Distance TOTALE	19,13
SECTION 1/2/3				CH 2/5/8	Temps Imparti (H,mn)	0H30
					Moyenne Horaire	38,26
DISTANCE		DIRECTION		INFORMATIONS		DISTANCE TOTALE
TOTALE	PARTIELLE					DEGRESS.
6,808	1,423					12,322
9,228	2,420					9,902
9,606	0,378					AES 9,524
9,96	0,35					9,170

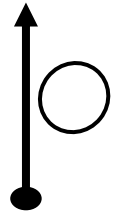
ETAPE 1		AUBIGNAC à LA BAUME		ES 1/4/7	Distance TOTALE	19,13
SECTION 1/2/3				CH 2/5/8	Temps Imparti (H,mn)	0H30
DISTANCE		DIRECTION		INFORMATIONS		DISTANCE TOTALE
TOTALE	PARTIELLE					DEGRESS.
9,99	0,03				D 160 St PAUL la COSTE	9,14
10,10	0,11	  			D 160 ALES SRP	9,03
10,21	0,11				 SORTIE ZONE CASQUE	8,92
14,92	4,71				D 160 ALES	4,21
16,76	1,84				D 160 ALES	2,37

ETAPE 1		AUBIGNAC à LA BAUME		ES 1/4/7	Distance TOTALE	19,13
SECTION 1/2/3				CH 2/5/8	Temps Imparti (H,mn)	0H30
DISTANCE		DIRECTION		INFORMATIONS		DISTANCE TOTALE
TOTALE	PARTIELLE					DEGRESS.
17,70	0,94				D 160 LA BAUME	1,43
18,00	0,30				D 32 COL de la CROIX des VENTS	1,13
18,19	0,19				D 32 St GERMAIN de CALBERTE	0,94
19,06	0,87					0,07
19,13	0,94				CH  ES 2/5/8	0,00





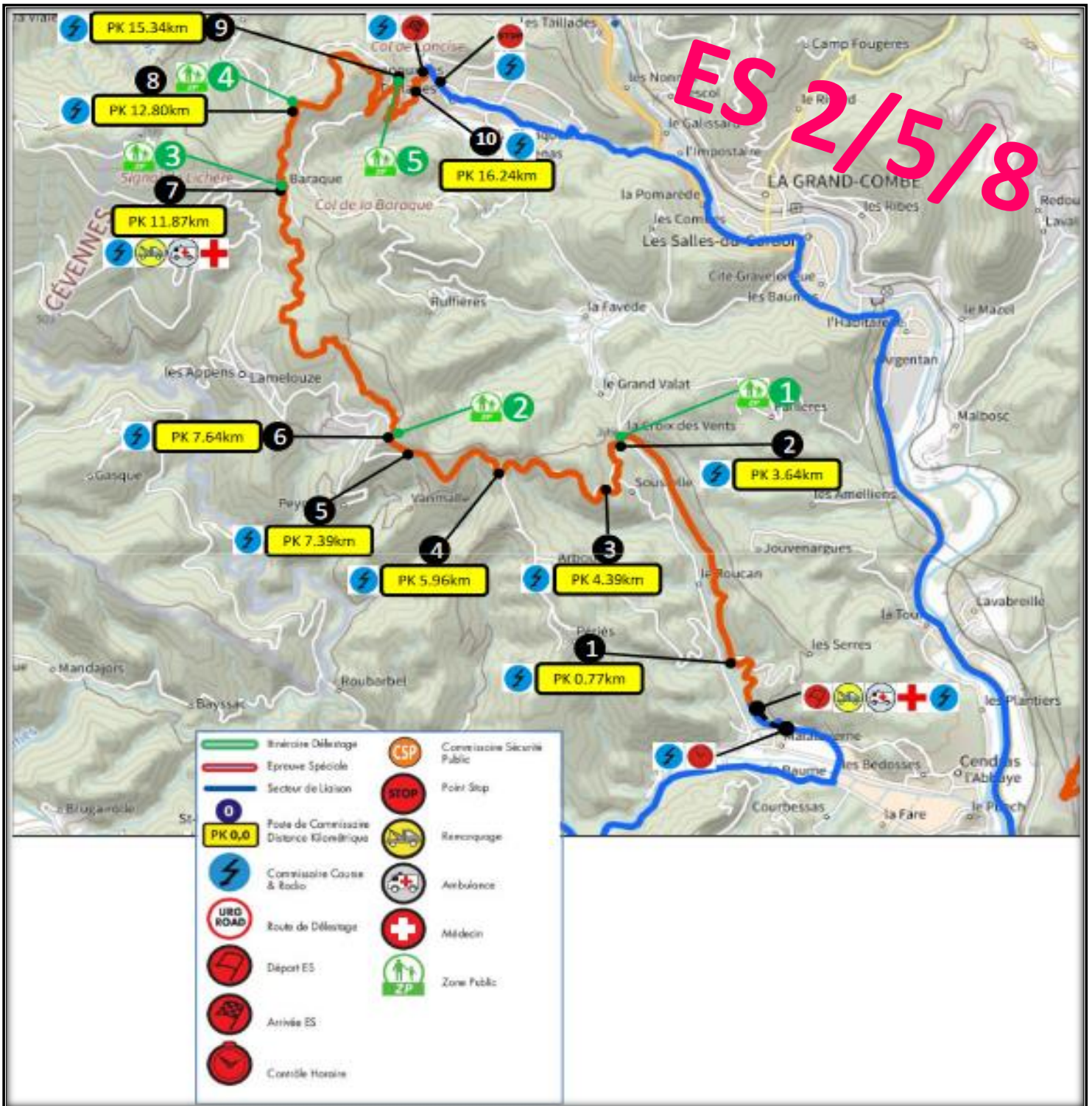



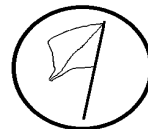



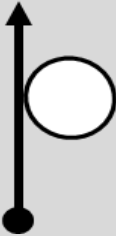

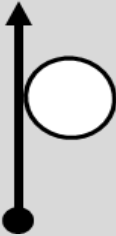
LA BAUME - BRANOUX

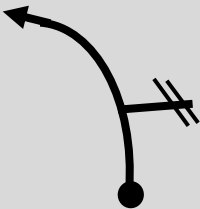
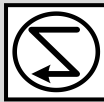

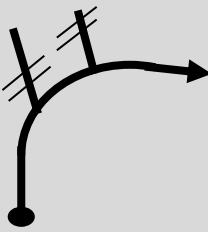

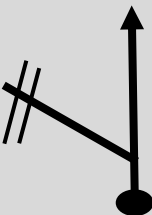



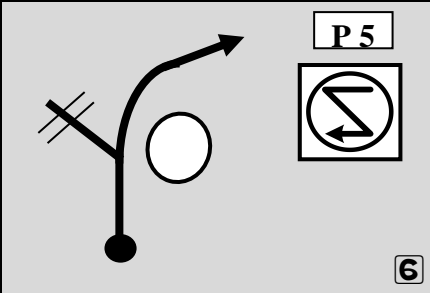

17,007 Km

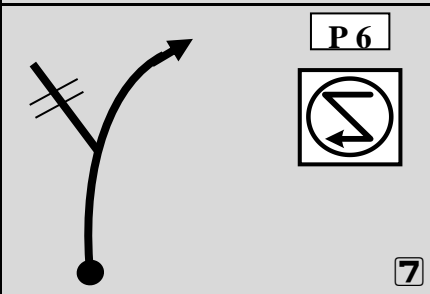

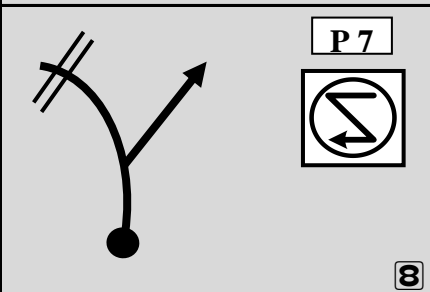

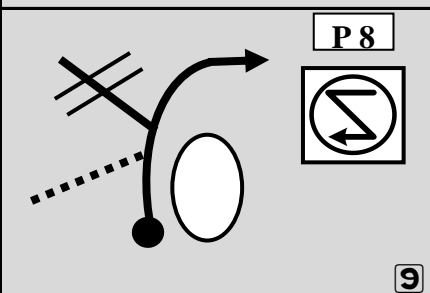

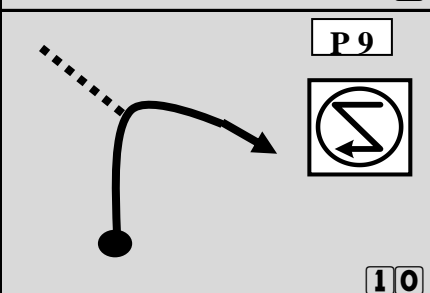



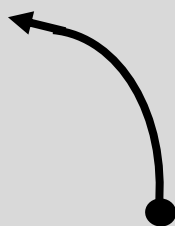



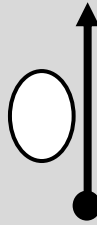

















ETAPE	1	LA BAUME à	CH 2/5/8	Distance TOTALE	0H03
SECTION	1/2/3	BRANOUX	ES 2/5/8	Temps Imparti (H,mn)	
				Moyenne Horaire	

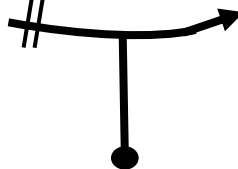

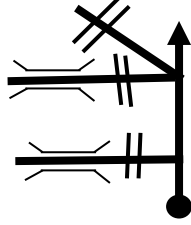

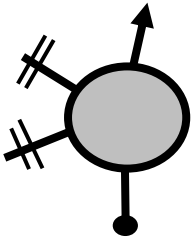



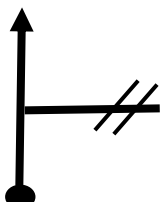

ETAPE 1		LA BAUME à SUPER SPECIALE POLE MECANIQUE		ES 2/5/8	Distance TOTALE	31,59
SECTION 1/2/3				CH 3/6/9	Temps Imparti (H,mn)	0H40
					Moyenne Horaire	47,38
DISTANCE		DIRECTION		INFORMATIONS		DISTANCE TOTALE
TOTALE	PARTIELLE					DEGRESS.
0,000	0,000					31,590
						
0,777	0,777	<p>P 1</p>  				30,813
		<p>P 2</p>  			<p>D 32</p> 	
3,690	2,913	<p>P 3</p>  			<p>Le Sollier (Soustelle)</p>	27,900
4,420	0,730	<p>P 4</p>  			<p>D 32</p> 	
6,072	1,652					25,518

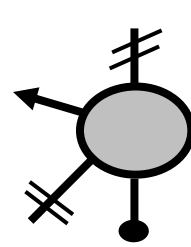
ETAPE 1		LA BAUME à SUPER SPECIALE POLE MECANIQUE		ES 2/5/8	Distance TOTALE	31,59
SECTION 1/2/3				CH 3/6/9	Temps Imparti (H,mn)	0H40
DISTANCE		DIRECTION		INFORMATIONS		DISTANCE TOTALE
TOTALE	PARTIELLE					DEGRESS.
7,516	1,444					24,074
7,761	0,245			D 32	St GERMAIN de CALB.	23,829
12,070	4,309			D 154	LA GRAND COMBE BRANOUX	19,520
13,022	0,952			D 154	LA GRAND COMBE BRANOUX	18,568
15,598	2,576					15,992

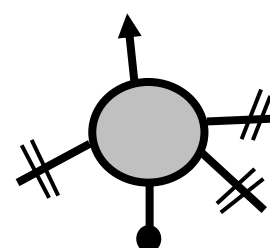
ETAPE 1		LA BAUME à SUPER SPECIALE POLE MECANIQUE		ES 2/5/8	Distance TOTALE	31,59
SECTION 1/2/3				CH 3/6/9	Temps Imparti (H,mn)	0H40
					Moyenne Horaire	47,38
DISTANCE		DIRECTION		INFORMATIONS		DISTANCE TOTALE
TOTALE	PARTIELLE					DEGRESS.
16,517	0,919	    				15,073
17,007	0,490	    		AES		14,583
17,29		  				14,30
17,40	0,11	  		BRANOUX	SRP	14,19
17,54	0,14	  				14,05

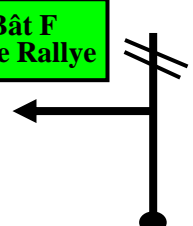
ETAPE 1		LA BAUME à SUPER SPECIALE POLE MECANIQUE		ES 2/5/8 CH 3/6/9	Distance TOTALE Temps Imparti (H,mn) Moyenne Horaire	31,59 0H40 47,38
SECTION 1/2/3		DIRECTION		INFORMATIONS		DISTANCE TOTALE DEGRESS.
TOTALE	PARTIELLE					
18,35	0,81				<div style="border: 1px solid black; padding: 5px; display: inline-block;"> <p style="background-color: yellow; display: inline-block; padding: 2px;">D 154</p> <p>BRANOUX (Commune Branoux les Taillades)</p> </div>	13,24
20,12	1,77				<div style="display: flex; flex-direction: column; align-items: center;"> <div style="background-color: red; color: white; padding: 2px; margin-bottom: 5px;">N 106</div> <div style="background-color: green; color: white; padding: 5px; margin-bottom: 5px;">ALES</div> </div>	11,47
21,26	2,91				<div style="background-color: green; color: white; padding: 5px; display: inline-block;">ALES</div>	10,33
23,04	2,92				<div style="display: flex; flex-direction: column; align-items: center;"> <div style="background-color: red; color: white; padding: 2px; margin-bottom: 5px;">N 106</div> <div style="background-color: green; color: white; padding: 5px; margin-bottom: 5px;">ALES</div> </div>	8,55
25,53	4,27				<p>SOURIEZ, VOUS ÊTES RADARIFIE</p> 	6,06

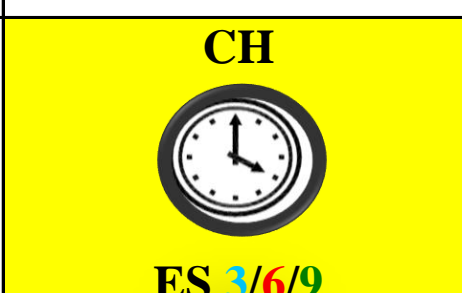
ETAPE 1		LA BAUME à SUPER SPECIALE POLE MECANIQUE		ES 2/5/8	Distance TOTALE Temps Imparti (H,mn) Moyenne Horaire	31,59 0H40 47,38
SECTION 1/2/3				CH 3/6/9		
DISTANCE		DIRECTION		INFORMATIONS		DISTANCE TOTALE DEGRESS.
TOTALE	PARTIELLE					
27,10	1,57		21			4,49
30,52			22			
30,77	3,67		23			0,82
31,59	1,07		24			0,00

SUPER SPECIALE PÔLE MECANIQUE





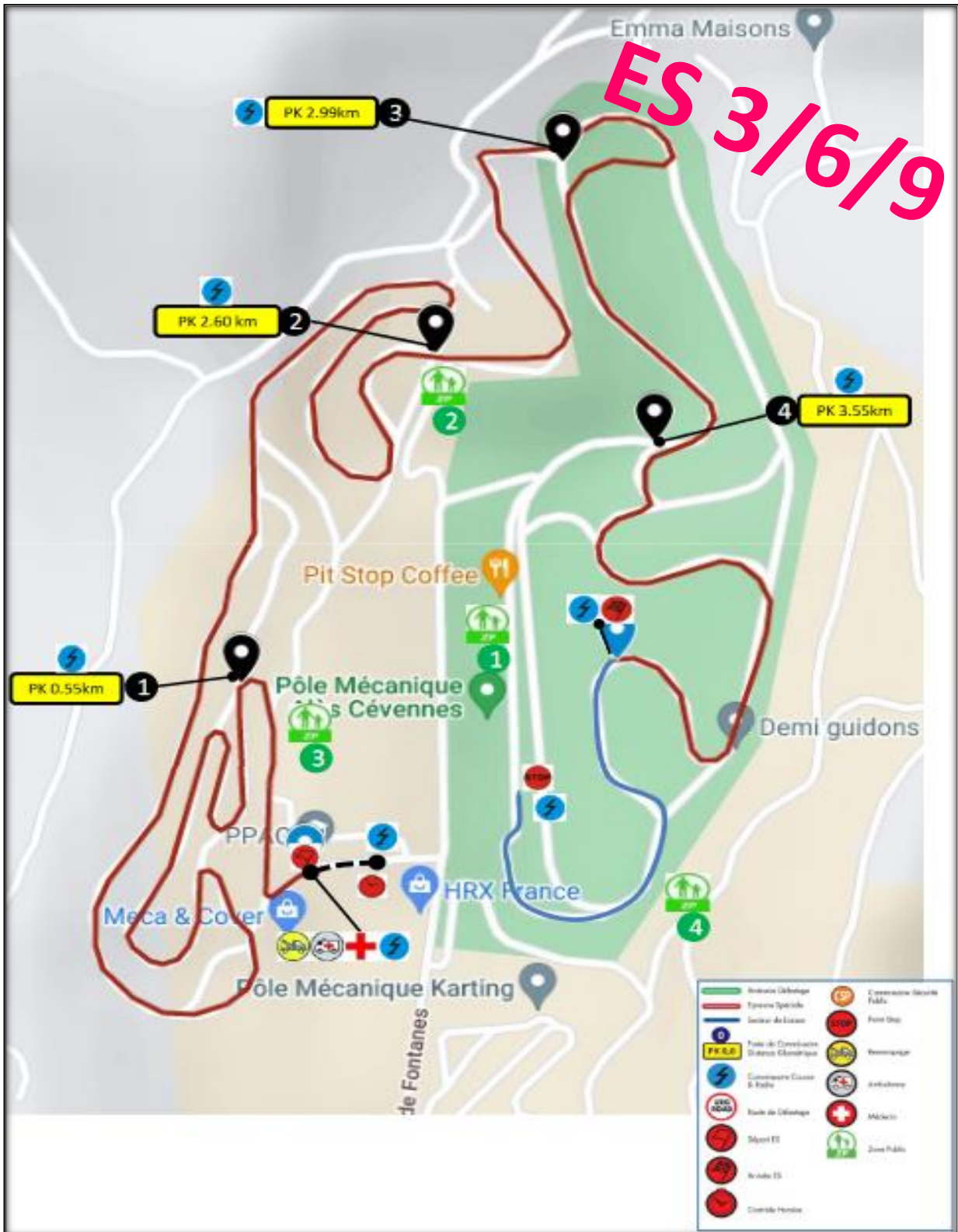



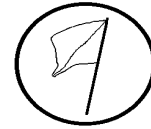



4,370 Km

ES 3/6/9



ETAPE 1	SUPER SPECIALE POLE MECANIQUE à ENTREE PARC REGROUPEMENT & FINAL	ES 3/6/9	Distance TOTALE Temps Imparti (H,mn) Moyenne Horaire	
SECTION 1/2/3		CH 3A/6A/9A		



ETAPE 1		POLE MECANIQUE Entrée Parc Regroup. à POLE MECANIQUE Sortie Assistance	CH 3/6A	Distance TOTALE	
SECTION 1/2			CH 3/6C	Temps Imparti (H,mn) 0H35	
DISTANCE		DIRECTION	INFORMATIONS		
TOTALE	PARTIELLE		DISTANCE TOTALE DEGRESS.		
			CH		ENTREE PARC REGROUPEMENT
			CH		SORTIE PARC REGROUPEMENT
			CH		ENTREE ASSISTANCE
			CH		SORTIE ASSISTANCE



Reprendre les tours à la page 5
AU 3 EME TOUR
ENTREE PARC FINAL



Félicitations



50e Rallye du Gard - Alès Agglomération

16 & 17 Juin 2023



*Nous vous remercions pour votre participation,
Rendez-vous pour une nouvelle édition,
L'équipe d'organisation et tous ses partenaires.*

Vous avez été victime d'un accident
Si vous avez besoin d'aide médicale ou matérielle
Présentez ce signe à tous les équipages qui passent
devant vous afin qu'ils informent le poste le plus proche.

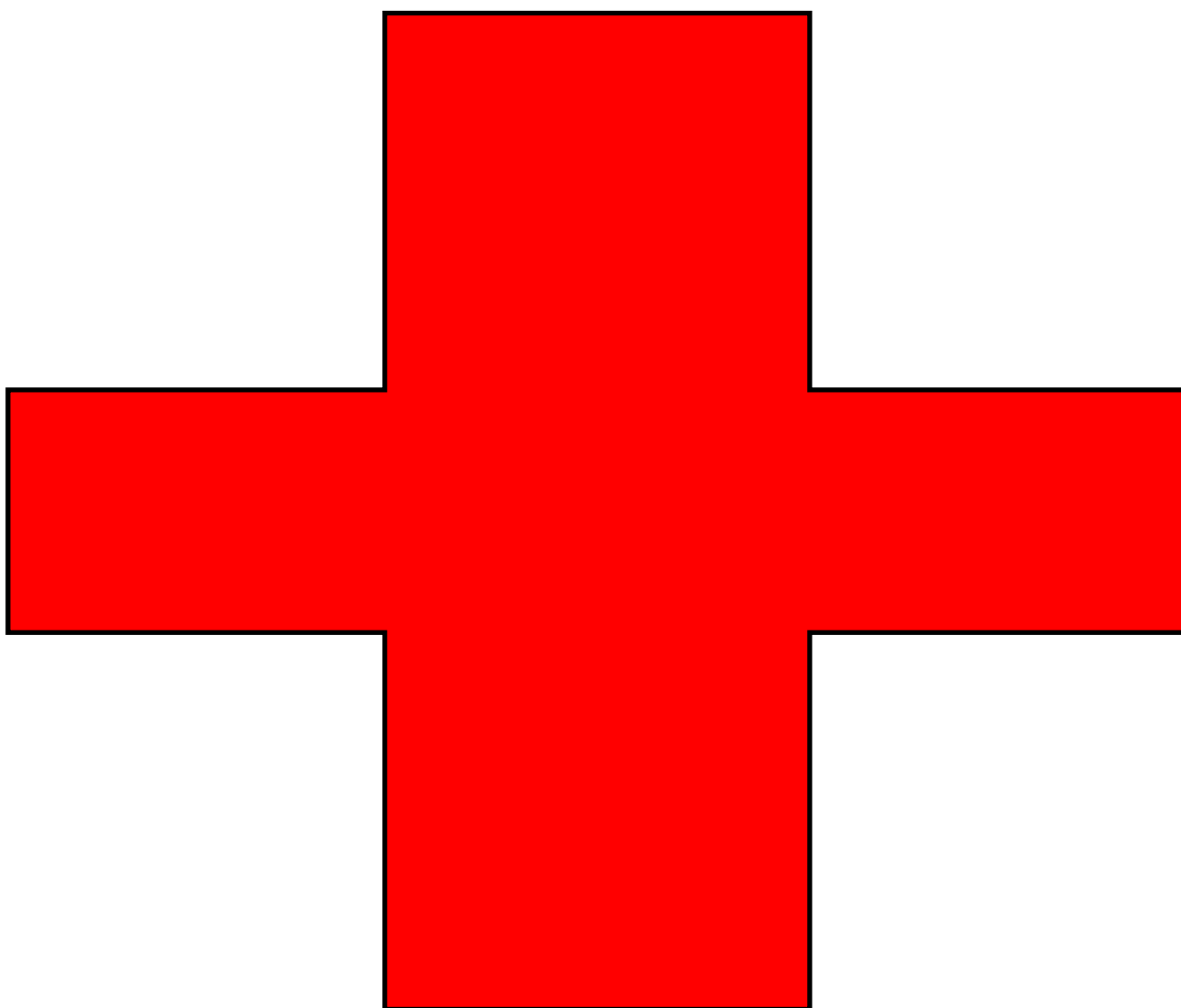

RALLYE

DU

GARD



**Vous avez été victime d'un accident
Si tout va bien et si vous n'avez pas besoin d'aide
Présentez ce signe à tous les équipages qui passent
afin de rassurer rapidement l'organisation.**

OK



RALLYE

DU

GARD

